

**FormDirect**<sup>TM</sup>  
In, on & around concrete



**BOSCARO**  
Construction Equipment

☎ 1300 659 830    🖱 [www.formdirect.com.au](http://www.formdirect.com.au)

Big expertise. Real convenience. Concrete commitment.

# WHO WE ARE

Form Direct is a leading, experienced partner for concrete construction projects of any size and complexity.

We supply specialist equipment and materials for the concrete building industry, along with a wide selection of on-site essentials.

Our comprehensive range of buy and hire options and proven expertise help you achieve results the simple and efficient way.

Our strong reputation comes from years of working closely with concreters, builders, project managers and civil construction teams across Australia.

At Form Direct, we pride ourselves on outstanding materials, supplies and equipment; steadfast service; and real precision. We know that reliability can make or break a project, so we ensure clear expectations are met from exacting estimations to readily available stock and spot-on delivery.



# OUR CONCRETE COMMITMENT

For us, **'concrete'** says it all. Through a solid and consistent demonstration of five key commitments, we support site productivity while bringing certainty, clarity and value to any project.



## Everyday reliability

We provide high-quality, reliable products and equipment that work. Maintained to ensure exceptional condition.



## Proactive partnership

We're invested in your success from beginning to end, with the experience and capabilities to tackle the most complex challenges.



## Fast, flexible & easy

You benefit from the efficiencies that flow from one supplier providing a full range of specialist products + a suite of site necessities + the choice to buy or hire + readily available bulk stock.



## Getting it right

We have built our reputation on precision and accuracy you can depend on — from on-time delivery to accurate paperwork.



## Industry insight

With Form Direct, you get the benefit of vast experience with our passion for bringing you the latest solutions.

## CONTENTS



Kibble Buckets..... 4



Mortar Tub ..... 5



Telescopic Crane Fork..... 6



Self Tipping Skip..... 7



Boat Skip..... 8



Stacking Skip ..... 9



Circular Skip..... 10



Galvanised Site Box ..... 11



Diesel Cement Mixer ..... 12



Diesel & Electric Cement Mixers..... 13



Petrol & Electric Cement Mixers ..... 14



Electric Cement Mixer..... 15

# BOSCARO KIBBLE BUCKETS

## CONCRETE KIBBLE

A versatile concrete bucket with lever discharge.

Optional accessories

- Side chute attachment
- Centre chute attachment including hose



Concrete Kibble C-99N



Hose/trunk for centre unload

Forklift base with two way entry



Chute for side unload

Code	Description
CNL-99	Chute for side unload
BASE99	Forklift base and hose for centre unload

Code	Dimensions	Weight Kg (empty)	Capacity Kg	Capacity Lt
C-99N	1300 (H) x 1250 Ø	170	2200	1000

Photos are for illustrative purposes only. EOM





## BOSCARO KIBBLE BUCKETS

### CONCRETE KIBBLE

Concrete bucket with central and side unloading.  
A versatile concrete skip with a levered discharge.  
Can be used as a side or central discharging.



Code	Dimensions	Weight Kg (empty)	Capacity Kg	Capacity Lt
CL-50	970 (H) x 1060Ø	97	1100	500

### PLASTIC MORTAR TUB

- Made of solid plastic.
- Can be moved by one person when empty.
- When full, can be lifted with a crane or forklift.



Code	Dimensions (mm)	Weight Kg (empty)	Capacity Litres	Capacity Kg
M-20	1080 (L) x 670 (W) x 510 (H)	15	200	400

# BOSCARO

## MANUAL TELESCOPIC CRANE FORK

- Height and width adjustable
- Can easily be used with mobile/truck cranes due to its lower height.

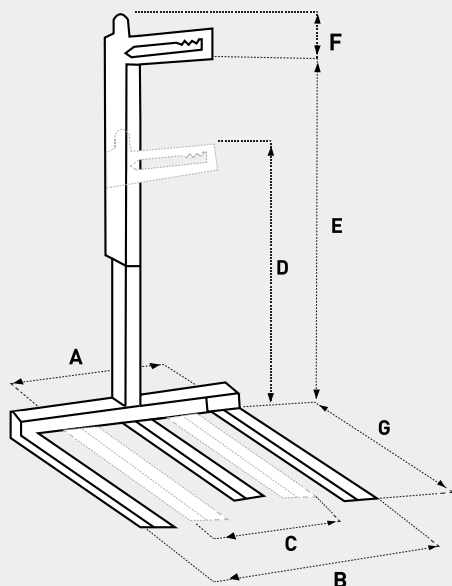

Code	Crane Weight Kg	Capacity Kg	A	B	C	D	E	F	G
MBR-20	160	2000	1000	1000	300	1200	1800	450	1000

# BOSCARO TIPPING SKIP

## SELF DUMPING FORKLIFT TIPPING SKIP

Forklift tipping skip with wheels designed to be used inside buildings for general site waste products.

- Automatic locking base.
- Safety chain to attach to forklift.



Code	Skip Weight Kg	Capacity Lt	A	B	C	D	E
BB-99	200	1000	1500	1070	1210	980	920
BB-160	300	1600	1500	1550	1210	980	920

# BOSCARO BOAT SKIP

## SELF DUMPING BOAT SKIP

These skips are used for general waste removal. The low loading height and drop down bale arm makes filling very easy.

The high quality of these boat skips permits an automatic unloading without a manual intervention by the crane operator with a special and modern system of release.

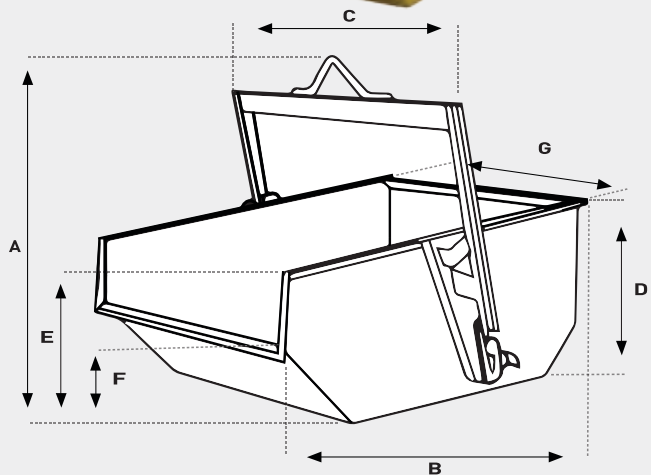
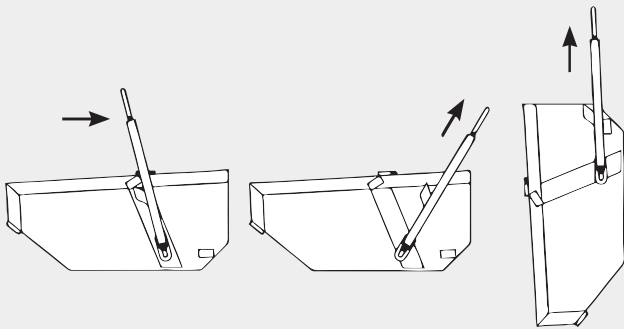

Code	Skip Weight Kg	Capacity Lt	Capacity Kg	A	B	C	D	E	F	G
A-60D	110	600	960	1050	1300	1150	600	490	270	1080
A-99D	230	1000	1600	1450	1700	1370	850	650	380	1280
A-150D	300	1500	2400	1250	1700	1420	850	850	600	1330

Photos are for illustrative purposes only. EOM



## BOSCARO STACKABLE BOAT SKIP

### STACKING SKIPS

For loading and unloading of material or construction equipments



Code	Dimensions	Weight Empty Kg	Capacity Kg
CR	2500 x 1100	210	1000

# BOSCARO CIRCULAR SKIPS

## CIRCULAR SKIPS

Circular skip used for waste removal.  
Fitted with two safety catches.  
When safety catches on the lifting arm are disengaged the skip will automatically empty in response to a change in the centre of gravity.

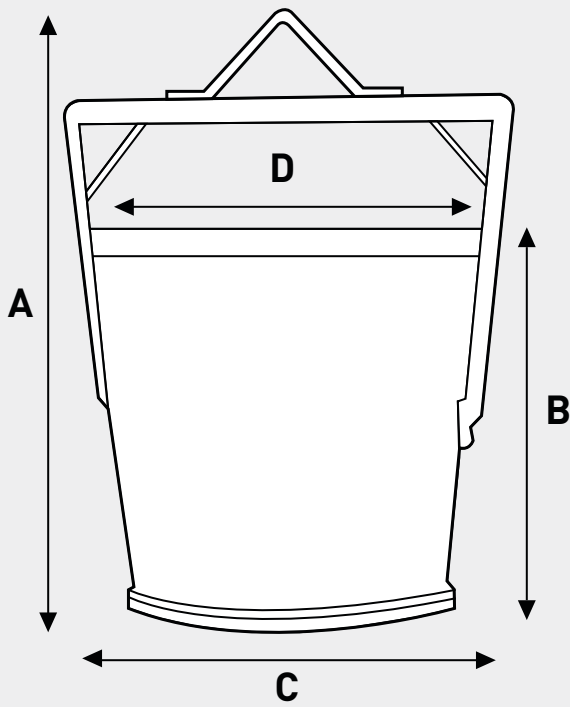

Code	Skip Weight Kg	Capacity Lt	Capacity Kg	A	B	C	D
BTB-75	180	750	1280	1600	950	1000	1150

## BOSCARO SITE BOX

### GALVANISED TOOL/SITE BOX

For loading and unloading of material or construction equipment.

- Lockable
- Use for transportation and/or storage

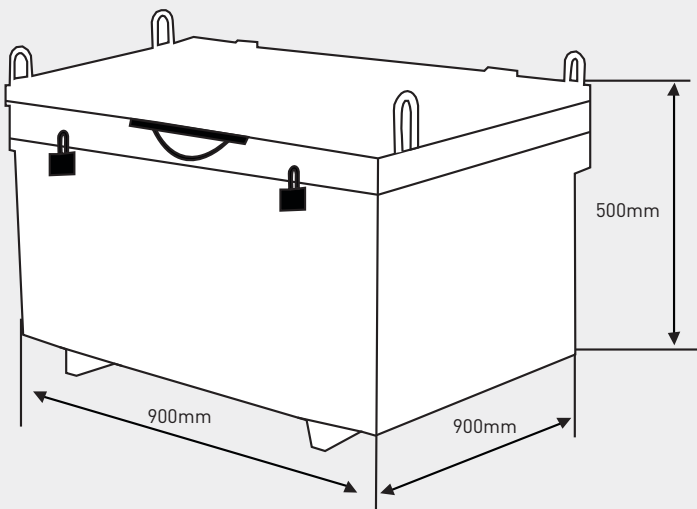

Code	Dimensions	Capacity Lt	Capacity Kg	Weight Empty Kg
PA-10.10ZN	900 x 900 x 500mm	420 Lt	500	80



# Boscaro Cement Mixers

Quality Italian Made Products for the construction industry. The Boscaro Cement mixers are safe to use because all the mechanical parts are protected by covers and all electrical components are isolated.

## DIESEL CEMENT MIXER

- Easy to use and maintain.
- Solid & Robust design.
- 17.7cuft / 0.5m<sup>3</sup>.
- Twin mixing blades are bolted to the bowl making blade replacement very easy.
- The bowl is balanced to enable higher mixing speeds.
- Drum rotation wheel has a foot lever brake to ensure safe, controlled tipping.

0.5M<sup>3</sup> Capacity!



Lombardini 15LD350 Diesel Motor



All Boscaro mixers feature removeable twin mixing blades and safe tipping method.

Code	Size	Motor	Hp	KW
S500D	17.7cuft	Diesel	9	6.6

Photos are for illustrative purposes only. EOM



## ELECTRIC AND DIESEL CEMENT MIXERS

- Easy to use and maintain.
- Solid & Robust design.
- 11cuft/0.31m<sup>3</sup> or 12.4cuft / 0.35m<sup>3</sup> sizes
- Twin mixing blades are bolted to the bowl making blade replacement very easy.
- The bowl is balanced to enable higher mixing speeds.
- Drum rotation wheel has a foot lever brake to ensure safe, controlled tipping.



Cima 80M Electric Motor



All Boscaro mixers feature removeable twin mixing blades and safe tipping method.

Lombardini 15LD350 Diesel Motor

Code	Size	Motor	Hp	KW
S360E	12.4cuft	Single Phase Electric	2	1.5
S360P	12.4cuft	Petrol	7.5	5.5





# BOSCARO CEMENT MIXER

## ELECTRIC AND PETROL CEMENT MIXERS

- Easy to use and maintain.
- Solid & Robust design.
- 6.7cuft / 0.19m<sup>3</sup> or 8cuft / 0.24m<sup>3</sup> sizes
- Twin mixing blades are bolted to the bowl making blade replacement very easy.
- The bowls are balanced to enable higher mixing speeds.
- Drum rotation wheel has a foot lever brake to ensure safe, controlled tipping.



Cima 80M Electric Motor



All Boscaro mixers feature removeable twin mixing blades and safe tipping method.

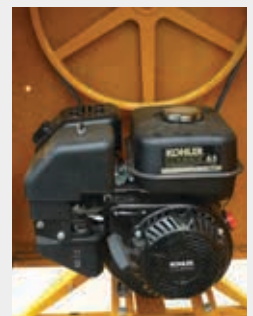

Kohler SH265 Petrol Motor

Code	Size	Motor	Hp	KW
S250E	8.5 cuft	Single Phase Electric	1.5	1.1
S250P	8.5 cuft	4 Stroke Petrol	6	4.4

Photos are for illustrative purposes only. EOM

## BOSCARO CEMENT MIXER

### ELECTRIC CEMENT MIXER

- Easy to use and maintain.
- Solid & Robust design.
- 5.3cuft / 0.15m<sup>3</sup>.
- Twin mixing blades for more thorough mixing.
- The bowls are balanced to enable higher mixing speeds.
- Drum rotation wheel has a locking system to ensure safe, controlled tipping.
- Folding legs for easy transportation



**Very portable**  
**Can be used indoors**

Code	Size	Motor	Hp	KW	Weight (empty)
S-150E	5 cuft	Single Phase Electric	0.5	0.37	60 Kg

## BOSCARO CUTTING AND BENDING MACHINES



Boscario 3 phase Cutting and Bending machine TP32/36-3Ph



Boscario 3 phase Bending Machine P36-3Ph



Boscario 3 phase Cutting Machine C36-3Ph



Please phone us for more information **1300 659 830**

**FormDirect**<sup>™</sup>  
*In, on & around concrete*



 **1300 659 830**

**FormDirect**<sup>™</sup>  
*In, on & around concrete*

**T** 07 4152 8788  
**F** 07 4152 8700  
**W** [www.formdirect.com.au](http://www.formdirect.com.au)

Head Office: 56 Enterprise Street  
Svensson Heights QLD 4670